

RAKATTACH MODEL CONFIGURATIONS

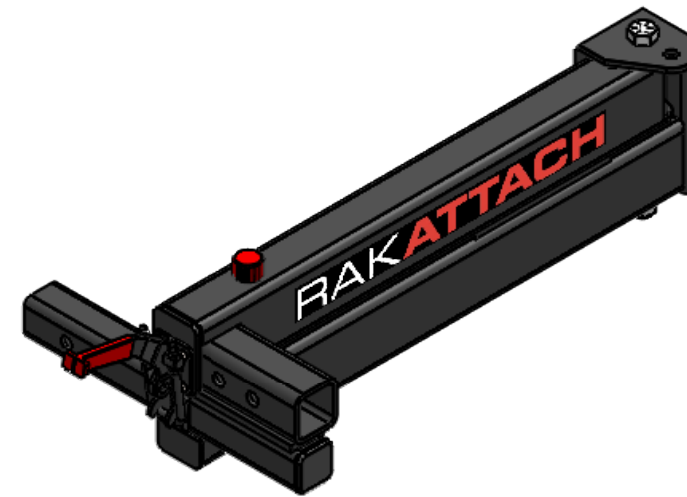

LARGE PASSENGER SIDE

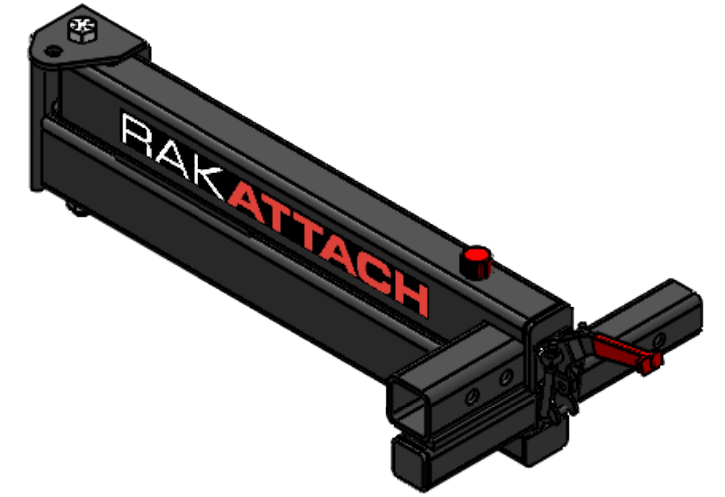

LARGE DRIVER SIDE

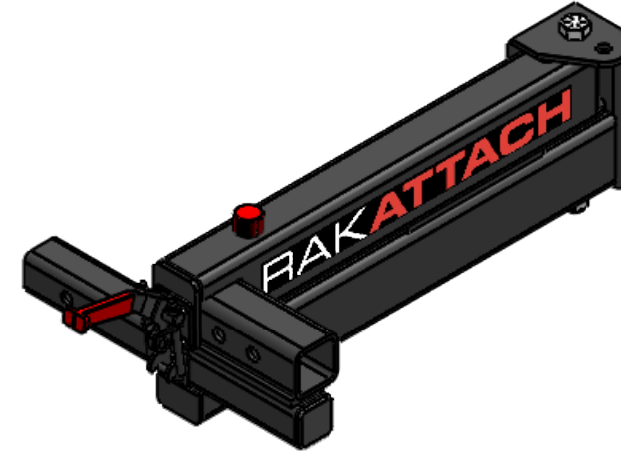

MEDIUM PASSENGER SIDE

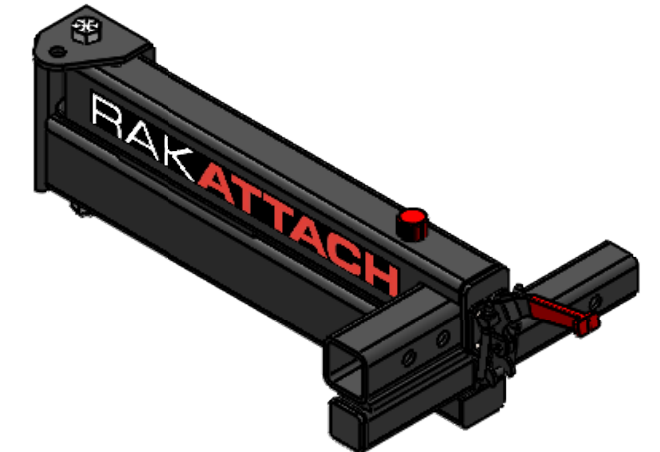

MEDIUM DRIVER SIDE



SMALL PASSENGER SIDE

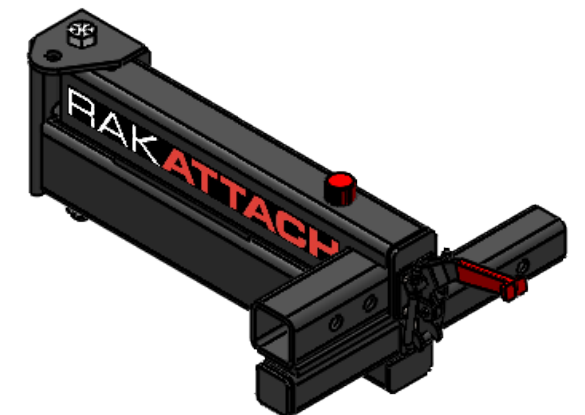

SMALL DRIVER SIDE

RAKATTACH FITMENT DRAWING

NOTE: PASSENGER/DRIVER DENOTE DIRECTION UNIT WILL SWING ON VEHICLE.

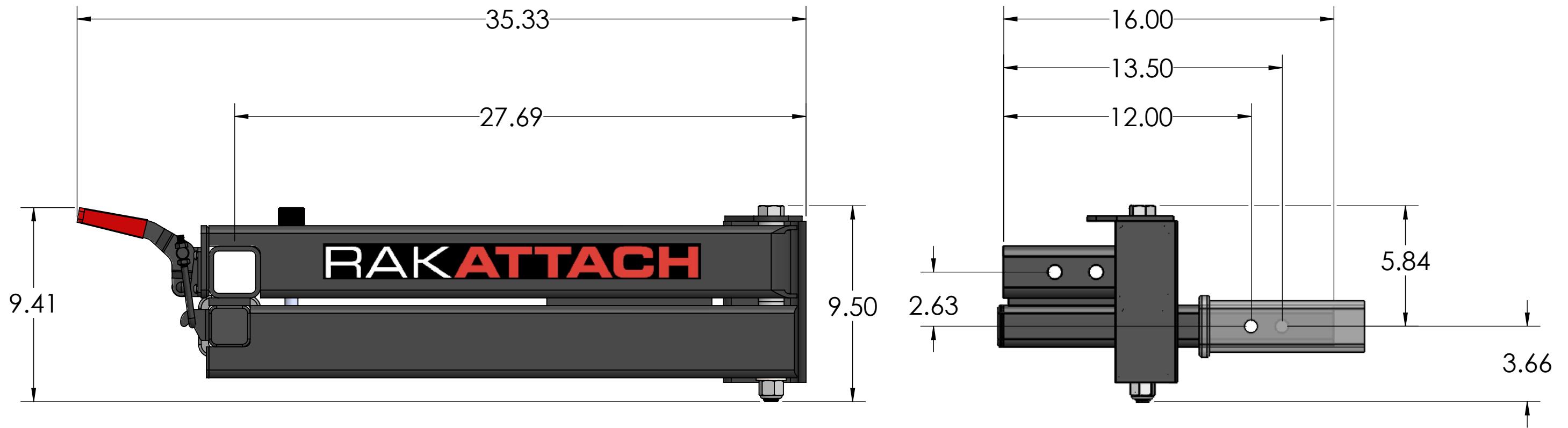

LARGE PASSENGER SIDE

LARGE DRIVER SIDE DIMENSIONS TO MATCH. ONLY DIFFERENCE IS THAT UNIT SWINGS TO OPPOSITE SIDE OF THE VEHICLE.
ALL DIMENSIONS IN INCHES.

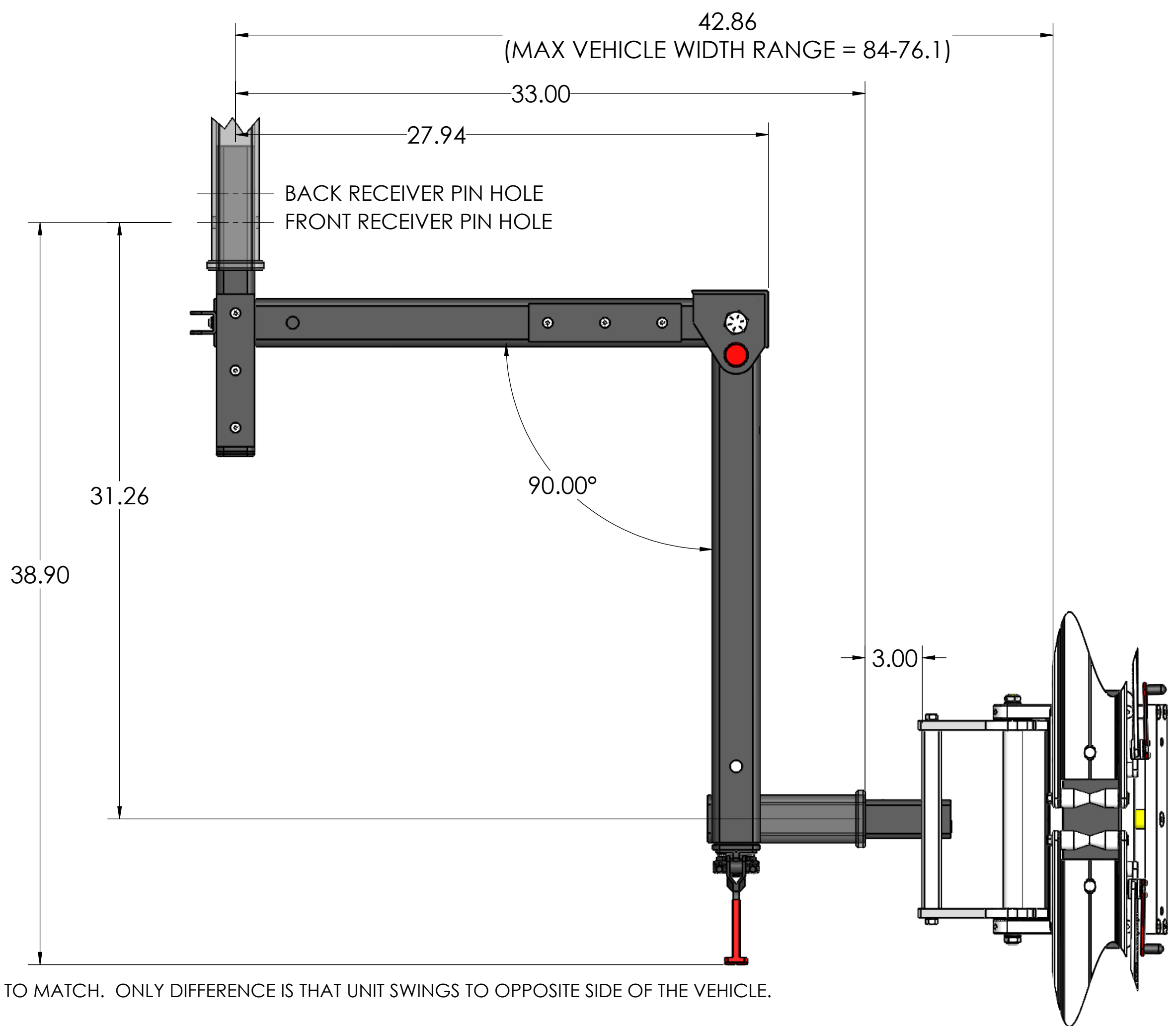

LARGE PASSENGER SIDE

LARGE DRIVER SIDE DIMENSIONS TO MATCH. ONLY DIFFERENCE IS THAT UNIT SWINGS TO OPPOSITE SIDE OF THE VEHICLE.
ALL DIMENSIONS IN INCHES.

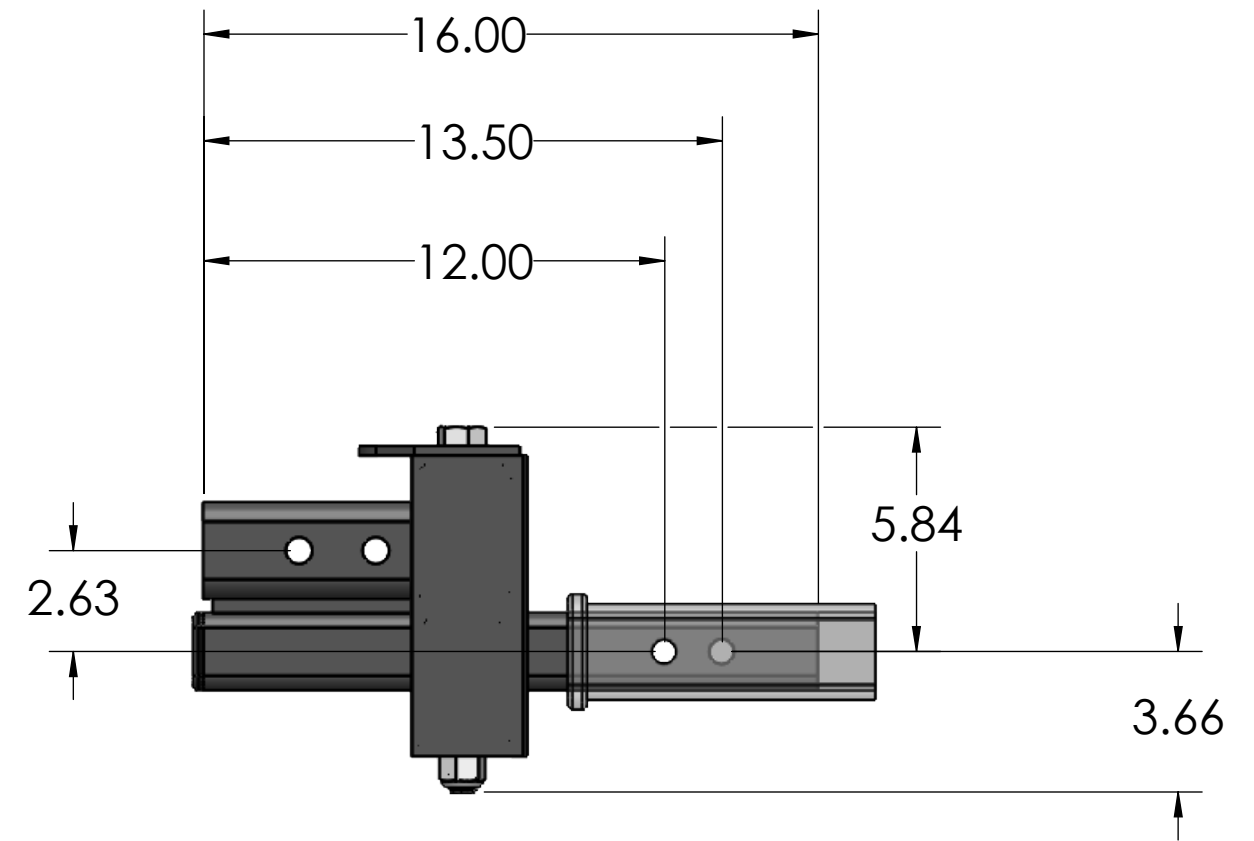
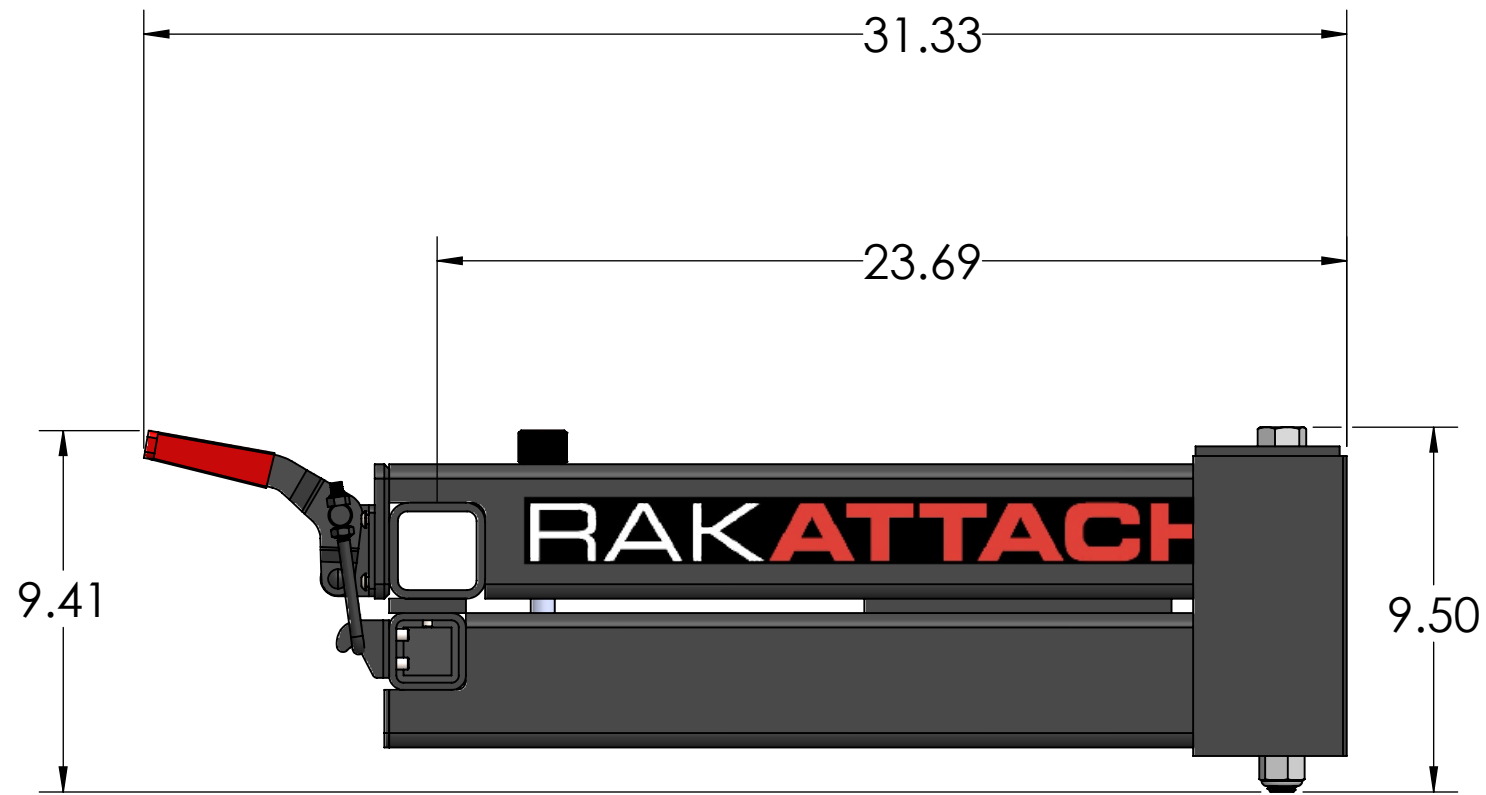

MEDIUM PASSENGER SIDE

MEDIUM DRIVER SIDE DIMENSIONS TO MATCH. ONLY DIFFERENCE IS THAT UNIT SWINGS TO OPPOSITE SIDE OF THE VEHICLE.
ALL DIMENSIONS IN INCHES.

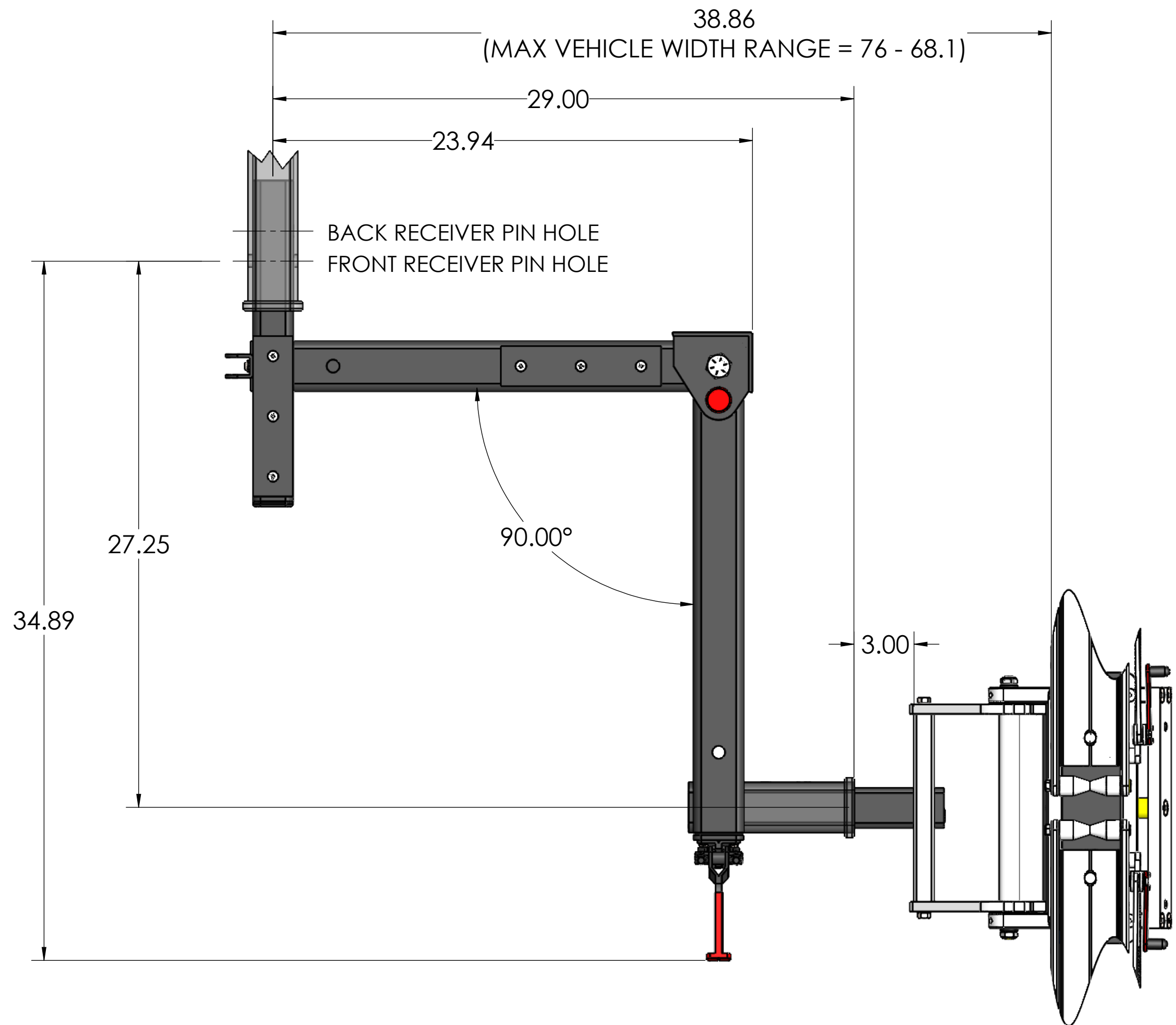

MEDIUM PASSENGER SIDE

MEDIUM DRIVER SIDE DIMENSIONS TO MATCH. ONLY DIFFERENCE IS THAT UNIT SWINGS TO OPPOSITE SIDE OF THE VEHICLE.
ALL DIMENSIONS IN INCHES.

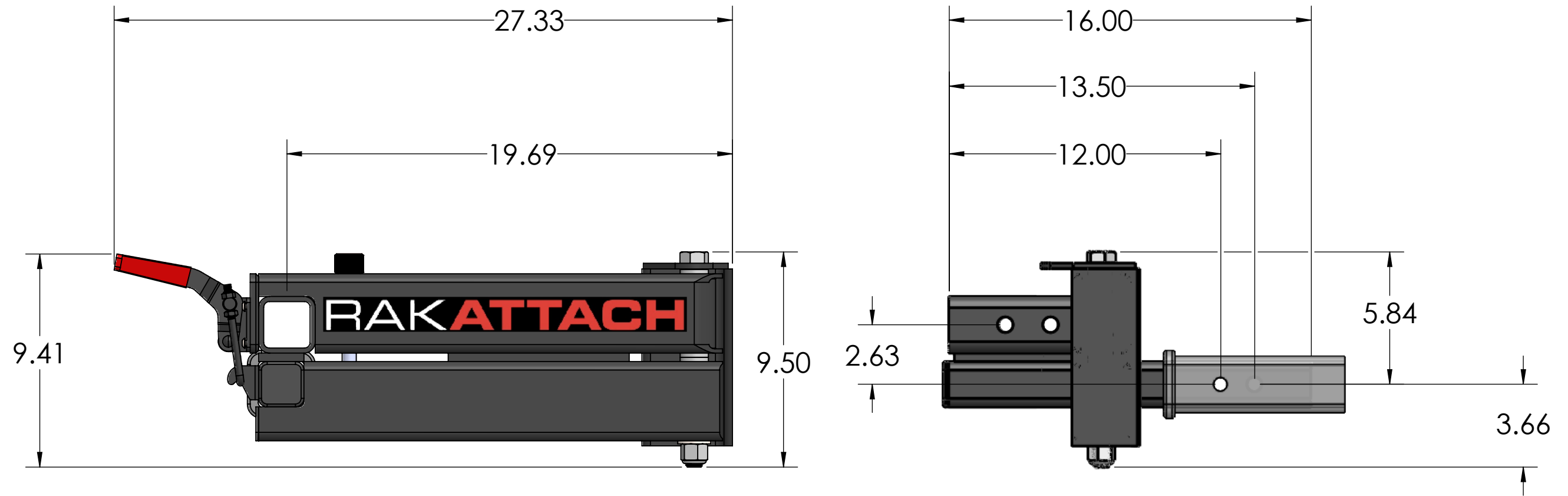

SMALL PASSENGER SIDE

SMALL DRIVER SIDE DIMENSIONS TO MATCH. ONLY DIFFERENCE IS THAT UNIT SWINGS TO OPPOSITE SIDE OF THE VEHICLE.
ALL DIMENSIONS IN INCHES.

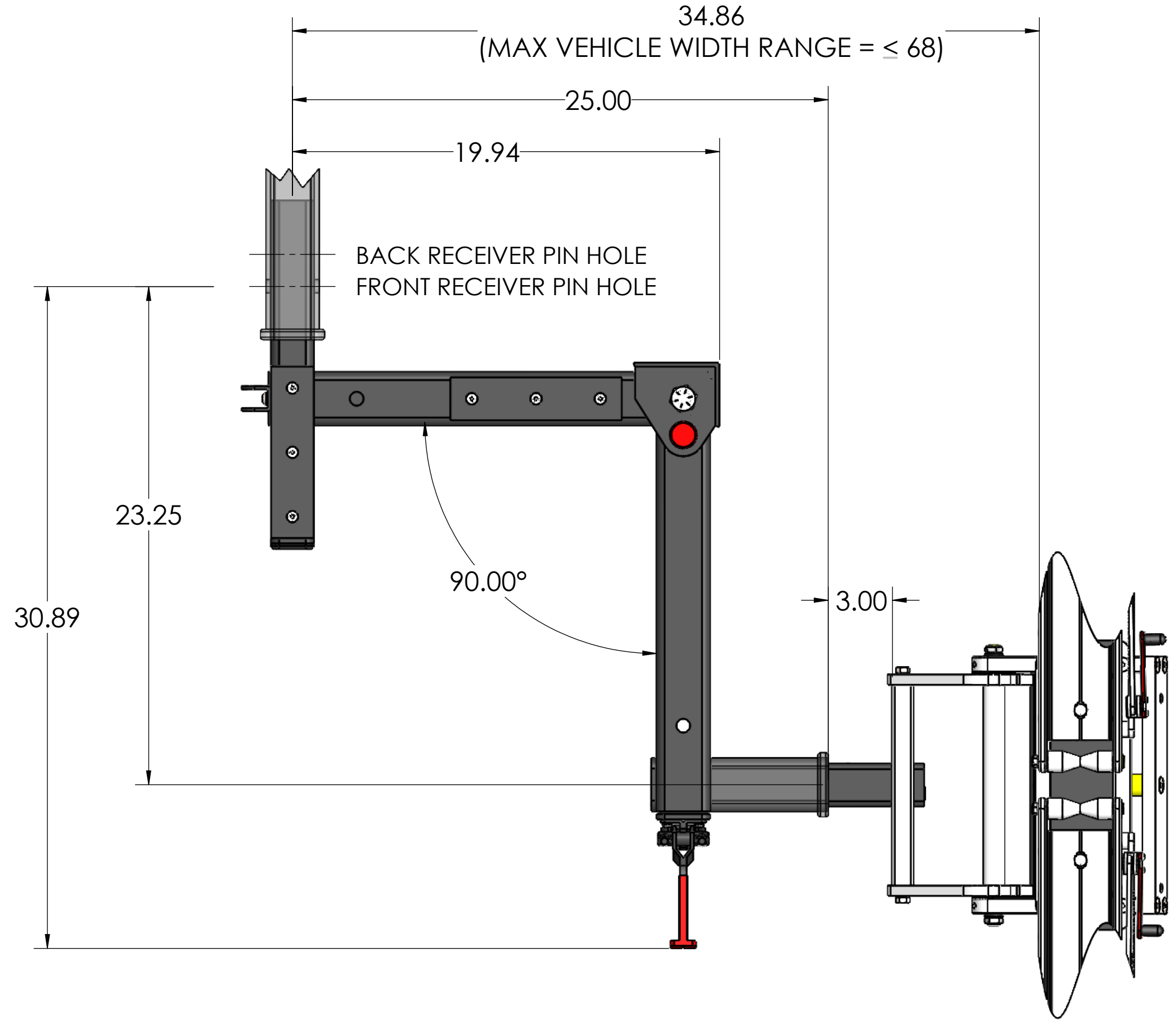

SMALL PASSENGER SIDE

SMALL DRIVER SIDE DIMENSIONS TO MATCH. ONLY DIFFERENCE IS THAT UNIT SWINGS TO OPPOSITE SIDE OF THE VEHICLE.
ALL DIMENSIONS IN INCHES.